

Heat On Demand Advantage® Plus Induction Heating Activator International Model ADV700E

Aladdin's Heat On Demand Advantage® Plus induction heating activator revolutionizes kitchen operations, giving you features, performance and efficiencies other meal-delivery systems just can't deliver.

Achieve long hot food holding times with or without a heated plate.^{1,2} Fast 12 second cycle delivers up to 5 trays per minute.



HEAT ON DEMAND

Advantage Plus



MINUTES
HOLD TIME



SECONDS
CYCLE TIME

Heat On Demand Advantage® Plus Benefits

- Hot food for higher patient satisfaction scores.
- Time-tested design and component reliability.
- Less heating equipment for a cooler kitchen.
- Simple operation for greater employee satisfaction.
- Induction technology provides energy savings.

Performance

- When using a heated plate and Allure® insulated dome, Heat On Demand Advantage Plus maintains food temperatures at or above 60°C for 73+ minutes¹, and for 60+ minutes² without using a heated plate.
- Consistent 12-second base heating cycle activates up to 5 bases per minute.
- Uses cool-to-the-touch Advantage bases that fit most standard 23 cm plates.
- No dish heater required for heating plates.²

Construction

- Durable stainless steel countertop design.
- Solid-state electronic controls for enhanced reliability.
- Robust polymer centering guide for hassle-free base insertion and removal.

Standard Features

- **LED status light** provides clear visual and audible cycle alerts: white / idle, red / base heating, green / base ready, yellow / error.
- **Automatic voltage calibration** adjusts for 380 to 440-volt power, so **voltage fluctuations will not affect base heating cycle time.**
- **Error prevention logic** eliminates the guesswork for easy operation.
- **Automatic power shut-off** conserves electricity when not in use.
- Internal fans keep electronics cool during heavy use.
- Base and activator diagnostics.
- Easy to remove washable air filter.



No reading required! The prominent **LED status light** displays a different vibrant color at every stage, glowing green when bases are ready, to make visual operation easy.



Sustainability

Efficient induction technology provides significant energy savings.

- Energy-efficient induction technology.
- Automatic shut-off conserves electricity when not in use.

Heat On Demand Advantage® Plus Induction Heating Activator International Model ADV700E

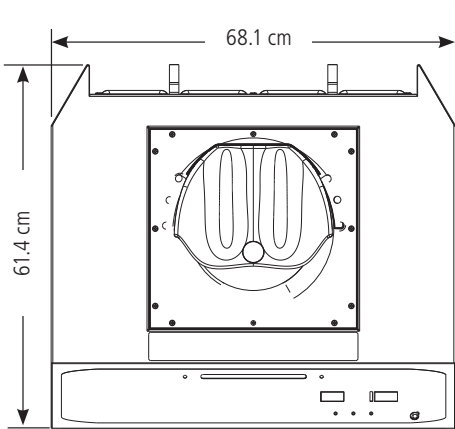

Plan View



Advantage Plus System

Advantage® Plus activators use Advantage bases which accommodate standard 23 cm dishware.

Visit aladdintemprite.com to view all color options for IHB26 Advantage bases.

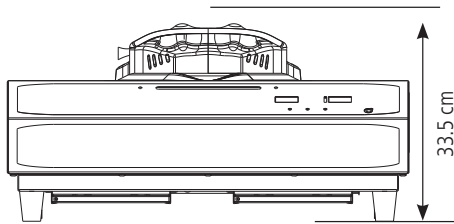

Front Elevation

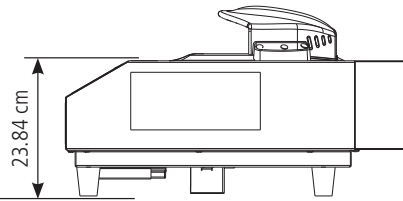

Side Elevation

Type 33/IP44
CEE16-6h²

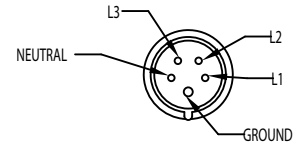

Pin and Sleeve Plug
5-Wire (3+N+G)³

Heat on Demand Advantage® Plus Technical Specifications

Model Number	Electrical ³	Cord Set/NEMA Plug ³	Width	Depth	Height	Weight	Shipping Weight
<input type="checkbox"/> ADV700E 400v model	Volts: 400 Hertz: 50/60 Phase: Three Max amp draw: (13.5) Min. amp capacity: 16	16A-6h Type 33/IP44 5-Wire (3+N+G) ³ 167.6 cm cord with pin and sleeve plug	68.1cm	61.4 cm	33.5 cm	27.7 kg	35.4 kg

¹311 grams of food input at 74°C with a 74°C heated plate, 73+ minutes hold time with Allure® domes.

²311 grams of food input at 74°C without a heated plate, 60+ minutes hold time with Allure® domes.

³Unit should be operated on a 16-amp dedicated circuit. Wall or raceway receptacle number Type 1385 (16A-6h), drop cord connector number Type 15A (16A-6h). **NORMAL OPERATION +10/-5% POWER SYSTEMS.**

⁴B-type RCD required (Non-linear Inductive Load).

⁵Facility to maintain stable power quality to include minimum circuit power factor of 80% under load.

⁶**TO PROTECT PRODUCT RELIABILITY:** Maintain electrical harmonic voltage THD (v) of 8% or less and harmonic current THD (I) of 15% or less under load.

Complies with CISPR 14/EN55014/EN6100.



Visit aladdintemprite.com/patents for patent information.

250 E. Main St. | Hendersonville, TN 37075 | Customer Service: 800.888.8018 | Tech Service: 800.888.5426 | Fax: 888.812.9956 | aladdintemprite.com

©2023 Aladdin Temp-Rite.® All rights reserved. Note: Specifications are subject to change without notice.



S230310ADV700E

an Ali Group Company



The Spirit of Excellence